

MODEL DSM-525

OPERATIONS & MAINTENANCE MANUAL



WB Johnson Instruments, LLC

4083 E 600 N

Rigby, ID 83442

Telephone: 208-557-6945

WEB: www.jradmeters.com

Fax: 208-557-6946

Table of Contents

<i>Introduction</i>	1
<i>Specifications</i>	2
<i>Operating Controls & Indicators</i>	3
Selector Switch Positions	3-1
DOSE/COUNT Toggle Switch	3-1
Speaker/Zero Toggle Switch	3-1
Data/Backlight Toggle Switch	3-1
Probe Connector	3-1
<i>Operating Instructions</i>	4
Before Operation	4-1
Instrument Operation Ratemeter	4-1
Instrument Operation Count 1 & Count 2	4-2
<i>Maintenance</i>	5
General	5-1
Location & Function of Calibration Controls	5-1
Adjusting Meter for CPM/CPS and R/Sv	5-1
Adjusting Meter HV	5-2
Disabling Alarms for Calibration	5-2
Adjusting Calibration Constant	5-3
Adjusting Dead Time	5-4
Adjusting Over Range Alarms	5-4
Adjusting Alarm Set Points	5-5
Timed Count	5-6
Adjust Count Time	5-6
Figures 1	5-6
Figures 2, 3, 4	5-7
Figure 5	5-8
<i>Technical Theory of Operation</i>	6
General Theory	6-1
Detector Signal – Diagnostics – Calibration Controls	6-1
High & Low Voltage Power Supplies	6-2
<i>Parts List</i>	7
LCD PC Board	7-1
Logic Board	7-2
Power Supply Board	7-3
<i>Schematics</i>	8
CPU Board	8-1
LCD Board	8-2
Power Supply Board	8-3

SECTION 1

INTRODUCTION

The Model DSM-525 is a portable microprocessor based digital scaler/ratemeter with two external probe connectors designed for use with scintillation, GM (Geiger-Mueller) and proportional type detectors for measuring ionizing radiation. The digital display has a 0.75" tall four digit Liquid Crystal Display (LCD) with moving decimal point. A five-position switch labeled OFF / RATEMETER 1 / SCALER 1 / RATEMETER 2 / SCALER 2 is used to select the desired operating mode.

Switch selectable display units (RATEMETER mode only) are represented in R/hr, Sv/hr, cpm, or cps with multipliers of micro (μ) or milli (m) for R/hr and Sv/hr and kilo (k) for cpm or cps. The display units are auto ranging allowing the readout to display a broad range of radiation levels.

The instrument has two external inputs that can be calibrated separately with Dead Time Compensation (DTC) in both cpm and dose rate modes of operation. An external toggle switch labeled COUNT/DOSE allows the instrument user to switch calibrated modes of operation just by toggling the switch to the desired mode COUNT or DOSE). Each input has its own adjustable HV power supply adjustable from 300 – 1500 vdc.

The instrument incorporates independent adjustable alarms for RATEMETER and SCALER operating modes for each input. A speaker produces a loud audible tone and a visual alarm is indicated on the LCD display for all activated alarms. All operating audible alarms can be temporarily disabled by toggling the ZERO switch.

The instrument is powered by six standard "AA" cell batteries. Durability is enhanced by heavy duty cast aluminum construction and the direct connection of the industrial type printed circuit boards.

SECTION 2

SPECIFICATIONS APPLY TO EACH PROBE

INPUT SENSITIVITY	0.050 vp-p
PROBE LINEARIZATION	Internal Adjustments for Calibration and Dead Time Customization for Each Probe
INPUT 1 PROBE RANGE	0 – 999.9 R/hr, 0 – 999.9 kcpm. 0 – 999.9 cps, 0 – 10mSv/hr
INPUT 2 PROBE RANGE	0 – 999.9 R/hr, 0 – 999.9 kcpm. 0 – 999.9 cps, 0 – 10mSv/hr
COUNT TIME	0 -2550 SECONDS IN 10 SECOND INCREMENTS
RANGE ADJUSTMENT	AUTO RANGING
ELECTRICAL LINEARITY	± 5% OF FULL SCALE
RESPONSE TIME FULL SCALE	FAST = 10 – 250 SEC. SLOW = 10-250 SEC.
DRIFT	LESS THAN 5%
TEMPERATURE COEFFICIENT	LESS THAN 0.2%/ DEGREE C
SEPARATE HIGH VOLTAGE	ADJUSTABLE - 300 - 1500 VDC REGULATION ± 1%
LOW VOLTAGE	+5 VDC & -5 VDC REGULATION ± 0.5 %
BATTERY	6 - "AA" ALKALINE
BATTERY OPERATION	200 HRS NOMINAL
LCD READOUT	4 DIGIT .75" (19mm) TALL
RS-232 DATA OUTPUT	9 PIN MINIATURE SUB-D CONNECTOR. DATA ON LCD READOUT DUMPED WHEN "DATA" SWITCH IS ACTIVATED ON FRONT PANEL.
LCD BACKLIGHT	30 SECONDS PER ACTIVATION FRONT PANEL "BACKLIGHT SWITCH"
TEMPERATURE RANGE	-20° C TO 50°C
HUMIDITY RANGE	5 - 95% NON CONDENSING
DIMENSIONS	7¼"(184mm) X 2 ¾" (70mm) H X 4 5/8"(118mm) DEEP
WEIGHT	3 POUNDS INCLUDING BATTERIES
HOUSING	16 Ga. ALUMINUM WITH HEAVY DUTY CARRYING HANDLE
HOUSING FINISH	LIGHT GRAY & DARK GRAY CATALYZED POLYURETHANE
CALIBRATION SECURITY	TOP AND BOTTOM ARE LATCHED TOGETHER

SECTION 3

OPERATING CONTROLS & INDICATORS

<u>SELECTOR SWITCH POSITION</u>	<u>FUNCTION</u>
OFF	ALL POWER DISCONNECTED TO THE INSTRUMENT
RATEMETER 1	NORMAL OPERATING RATEMETER MODE – CPM OR DOSE (BASED ON Cs-137 CALIBRATION) EXTERNAL PROBE
SCALER 1	TIMED COUNT (SCALER) MODE FOR EXTERNAL PROBE
RATEMETER 2	NORMAL OPERATING RATEMETER MODE – CPM OR DOSE (BASED ON Cs-137 CALIBRATION) INTERNAL PROBE
SCALER 2	TIMED COUNT (SCALER) MODE FOR INTERNAL PROBE

DOSE /COUNT TOGGLE SWITCH

Selects the operating mode of the ratemeter to measure in either CPM (cps) or DOSE (R/hr or Sv/hr) Probe response is automatically displayed in the correct (micro, milli or R/hr or sieverts) when DOSE mode for the probe that has been selected on the COUNT/DOSE SELECTION SWITCH. Operation in the CPM mode will display CPM (cps) for the probe that has been selected.

SPEAKER/ZERO TOGGLE SWITCH

Switch is momentary toggle switch with the center neutral. Momentary operation in speaker direction turns speaker on or off. Momentary operation in zero direction instantly disables the **AUDIBLE OPERATIONS ALARM. THE AUDIBLE ALARM WILL REMAIN DISABLED UNTIL THE SIGNAL FALLS BELOW THE SETPOINT AT WHICH TIME THE ALARM CIRCUIT WILL RETURN TO NORMAL OPERATION. OPERATION OF THE SWITCH IN THE ZERO DIRECTION FOR AT LEAST 3 SECONDS WILL ZERO THE INDICATION ON THE LCD.**

DATA/BACKLIGHT TOGGLE SWITCH

Switch is momentary toggle switch with the center neutral. Momentary operation in data direction provides the data being displayed on the LCD to the RS-232 DATA OUTPUT CONNECTOR. Momentary operation in the BACKLIGHT direction will light the LCD BACKLIGHT FOR 30 seconds. BACKLIGHT switch can be operated at the end of each 30 second cycle for another 30 second period for as long as necessary. Continued operation of the BACKLIGHT will greatly reduce the instruments battery life.

PROBE CONNECTOR FRONT PANEL

BNC type receptacle FOR BOTH PROBE INPUTS.

SECTION 4

OPERATING INSTRUCTIONS

BEFORE OPERATION

The DSM-525 HIGH VOLTAGE and GAIN are adjusted to the operating characteristics of the probes supplied with the meter. **IF THE DSM-25 IS PURCHASED WITHOUT PROBES IT WILL NOT BE CALIBRATED AND WILL HAVE THE FACTORY DEFAULT SETTINGS FOR THE EXTERNAL PROBE INPUT.** The GAIN (input sensitivity) is adjusted to 0.050v-pp. with an input sensitivity of 0.050 v p-p. These high voltage and gain settings are satisfactory for operation with the many probes but can produce large errors if the DSM-525 is not calibrated with each probe attached to the system. Refer to the MAINTENANCE SECTION for High Voltage adjustment procedure and calibration of the system. Be sure the R/Sv and the CPM/CPS switch has be set to the proper units before calibrating the system. Figure 4 shows the location of the switch on the LCD pc board.

NO OTHER CHECKS ARE NECESSARY PRIOR TO OPERATING THE DSM-525 EXCEPT TO OBSERVE THE DIAGNOSTIC INDICATORS IN THE LCD DISPLAY WHEN THE UNIT IS FIRST TURNED ON. The internal microprocessor analyzes the internal parameters for a few seconds when the instrument is first turned on and during the instruments operation. All range, battery & probe diagnostic are turn on momentarily during start-up to show they are working. The display then reverts to NORMAL operation. The diagnostic circuits connected to the BATT & PROBE indicators continuously monitor the Circuitry for out of range operation. Battery voltage below 6.8vdc will light the BATT Symbol on the LCD. SATURATION of a GM detector in high radiation fields will light the FAULT light. Exceeding the normal operating range of a probe in the DOSE mode will result in an audible beep every few seconds until the radiation field is reduced within the operating limits for the probe.

INSTRUMENT OPERATION – RATEMETER

NOTE: THE GSM-525 HAS 2 SEPARATE MEASURING SYSTEMS (DETECTORS). ONCE CALIBRATED OPERATION IS COMPLETEY AUTOMATIC AND ONLY REQUIRES THE CORRECT MAIN SELECTOR SWITCH POSITION

The **EXTERNAL PROBES** must be connected to the **EXTERNAL BNC** receptacles.

NOTE: FAILURE TO CONNECT THE PROBES CORRECTLY WILL INVALIDATE THE CALIBRATION.

Adjust the MAIN SELECTOR switch to RATEMETER 1 OR RATEMETER 2 for normal ratemeter type operation.

Depress the SPEAKER/ZERO towards SPEAKER if an audible “tick” for each input pulse is desired (to turn of the “tick” depress the switch again towards SPEAKER)

Select the mode of operation COUNT or DOSE (Based on Cs-137 calibration) with the COUNT/DOSE MODE SWITCH. DOSE includes linearization & DEAD TIME for the probe. Both corrections are automatically incorporated in the calibration procedure for each probe.

NOTE: ALL PROBES USING GM DETECTORS CAN BE DOSE CALIBRATED REFERENCED TO Cs-137. ONLY SOME OF THE PROBES USING SCINTILLATION DETECTORS CAN BE DOSE CALIBRATED, PRIMARILY FOR MICRO R MEASURMENTS. MOST SCINTILLATION PROBES MUST BE OPERATED IN THE CPM OR COUNT MODE IF THEY ARE NOT DOSE CALIBRATED.

The LCD READOUT can display the probe signals in CPM, CPS, ROETGEN AND SEIVERTS. When calibrating the system the decision to operate in CPM or CPS and ROETGEN OR SEIVERTS MUST BE MADE AND THE APPROPORATE SWITCHES ADJUSTED BEFORE THE SYSTEM IS CALIBRATED. FIGURE 4 SHOWS THE LOCATION OF THE R/Sv SWITCH AND THE CPM/CPS SWITCH.

INSTRUMENT OPERATION – SCALER 1 OR SCALER 2

The Scaler mode will count each individual pulse from the probe and display the count on the LCD. The system will be activated when the MAIN SELECTOR SWITCH is placed in the SCALER 1 or SCALER 2 position. **MAKE SURE YOU HAVE SELECTED THE DETECTOR YOU WANT TO COUNT.**

To start another count depress the ZERO SWITCH FOR AT LEAST 3 SECONDS. COUNTING will appear on the display and continue until the count cycle is complete. When the counting period is complete COUNT will appear indicating the cycle is complete.

If the system is adjusted to 0 seconds counting time then the system will continue to count as long as the MAIN SELECTOR SWITCH IS IN THE SCALER POSITION. See how to set count time SECTION 5.

SECTION 5

MAINTENANCE

GENERAL: The DSM-525 Digital Survey Meter has an two external probe inputs that operate independently as CPM/CPS RATEMETER, DOSE CALIBRATED RATEMETER, SCALER WITH TIMED COUNTING FUNCTIONS. Each PROBE can be calibrated independently utilizing probes that require 2 different High Voltages for correct operation. Once the inputs have been calibrated the only operator intervention required is to select the probe with the MAIN SELECTORS SWITCH ON THE FRONT PANEL. No external devices are required to calibrate the system except a NIST traceable radioactive source and electronic pulse generator. ALL CONTROLS NECESSARY TO CALIBRATE THE DSM-525 ARE LOCATED ON THE PC BOARDS OF THE SYSTEM.

LOCATION AND FUNCTION OF CALIBRATION CONTROLS

GENERAL: The calibration procedure for the DSM-525 utilizes only 3 potentiometers and 2 switches to calibrate all of the DSM-525 functions. FIGURE 1 SHOWS THE GENERAL LOCATION OF THESE CONTROLS. SW4 located on the left side of the top pc board (next to SW5) selects the function to be calibrated. SW4 positions are as follows:

- POSITION #0** NORMAL OPERATING POSITION
- POSITION #1** DISPLAY & EDIT COUNT TIME 0 - 2550 SECONDS (10 SECOND INCREMENTS – ADJ – P1
- POSITION #2** DISPLAY & EDIT OPERATIONAL ALARM (5% - 95%) ADJ – P1 COARSE – P2 FINE
- POSITION #3** DISPLAY & EDIT OVER RANGE ALARM ADJ – P1 COARSE – P2 FINE
- POSITION #4** DISPLAY & EDIT CALIBRATION CONSTANT – ADJ – P1 COARSE – P2 FINE – P3 TENTHS
- POSITION #5** DISPLAY & EDIT DEAD TIME - ADJ – P3
- POSITION #6** DISPLAY & EDIT HIGH VOLTAGE - MAIN SELECTOR TO #1 PROBE – ADJ #1 HV MAIN SELECTOR TO #2 PROBE – ADJ #2 HV – DISPLAY READS IN VOLTS
- POSITION #7** DISPLAYS SOFTWARE NUMBER INSTALLED IN INSTRUMENT
- POSITION #8** DISPLAY & EDIT FAST & SLOW TC – SET TO FAST ADJ P1 TO (10 – 250 SECONDS) SET TO SLOW ADJ P1 TO (10 – 250 SECONDS
- POSITION #9** DISPLAY & EDIT LCD REFRESH RATE (8 = 0.8 SECONDS TO 30 = 3.0 SECONDS ADJ P1 TO DESIRED REFRESH RATE

SW5 (located beside SW4 Figure 2) - it is utilized to **ACTIVATE & SAVE CALIBRATION SETTINGS** of the function selected by SW4 (***CAL is visible in the upper center of the display when SW5 activates the calibration function***) after desired settings are achieved they can be saved to the meters data base by pressing SW5 (***CAL will now disappear from display***)

Once a function has been selected by SW4 and activated by SW5 the potentiometers P1, P2 & P3 are utilized to input the calibration data. Once these potentiometers have calibrated the function SW5 is depressed and the data is saved. This process is repeated for each SW4 position using the same P1, P2, & P3 for all data input. Figure 3 shows the location of all the calibration components.

ADJUSTING THE METER FOR CPM/CPS AND R/Sv OPERATION

The switches that adjust the DSM-525 for Roentgen or Sieverts are located on the LCD pc board. To access these switches remove the DSM-525 from its housing. Looking at the bottom of the instrument with the LCD at the top the CPM/CPS switch is on the left side of the LCD pc board. The side of the board near the LCD will have CPS and CPM slide the small black switch lever towards the type operation desired.

The switch that selects Roentgen or Sieverts is on the right side of the LCD pc board located directly above the push button switch SW5. Slide the small black switch lever in the direction of the desired units of measurement (mR/hr or Sieverts).

This completes the adjustment of the DOSE UNITS AND COUNTING UNITS THAT WILL BE DISPLAYED ON THE LCD.

ADJUSTING THE HV FOR EACH PROBE INPUT (FIGURE 1, 2 & 3)

Remove the DSM-525 from its housing.

Determine if the HV that is required to operate PROBE 1 is correct.

Adjust the MAIN SELECTOR SWITCH TO RATEMETER 1 POSITION

Using a small screwdriver adjust SW4 to Position #6. The number displayed will be the HV on the PROBE 1. Adjust the #1HV potentiometer to read the required HV (± 10 vdc) on the display.

Adjust the MAIN SELECTOR SWITCH TO RATEMETER 2 POSITION.

Adjust the #2 HV potentiometer to the required HV (± 10 vdc) on the display.

Adjust SW4 to the POSITION #0.

THIS COMPLETES THE ADJUSTMENT OF THE HV FOR EACH PROBE.

DISABLING THE ALARM & OVERANGE ALARM BEFORE CALIBRATION

To disable the OVER RANGE & REGULAR ALARM before calibrating adjust the MAIN SELECTOR switch to RATEMETER OR COUNT depending on which alarms you want disabled.

To disable the OVER RANGE ALARM adjust SW4 to Position #3 and depress SW5 so that "CAL" is visible on display

Adjust P1 & P2 until the display indicates 0.

Depress SW5. This completes disabling the OVERRANGE ALARM.

To disable the REGULAR ALARM

Leave the MAIN SELECTOR SWITCH at the same setting as was used to disable the OVER RANGE ALARM

Adjust SW4 to Position #2 and depress SW5 until the "CAL" is visible on the display

Adjust P1 & P2 until display indicates 0. Depress SW5 to save the reading.

ADJUSTING THE CALIBRATION CONSTANT FOR THE PROBES (FIGURE 1 & 2)

GENERAL: The CALIBRATION CONSTANT adjustment is the CALIBRATION POINT for the LOW END OF THE PROBES OPERATING RANGE. This adjustment is completed utilizing **P1, P2&P3**. **P2** acts as a COURSE adjustment and **P1** acts as a FINE adjustment. **P3** is utilized to adjust the 0.1 part of the display these potentiometers will become active for the calibration process when **SW4** is in the correct Position and SW5 is depressed. The word "**CAL**" on the display will be visible when **SW5** has been depressed and the meter is in the CALIBRATION MODE.

CAUTION: **SW5 MUST BE DEPRESSED AT THE END OF THE ADJUSTMENT OR THE DATA WILL NOT BE SAVED.**

RATEMETER 1 PROBE CC ADJUSTMENT

Remove the DSM-525 from its housing

Determine the DOSE range of the probe that will be calibrated for the RATEMETER 1 position.

Attach Probe to the PROBE 1 BNC input.

Adjust the MAIN SELECTOR SWITCH TO THE RATEMETER 1 POSITION.

Adjust SW4 to the Position #4. Depress SW5 so that "CAL" is visible on display.

NOTE: GM TYPE PROBE'S CALIBRATION CONSTANT MUST BE CALIBRATED IN A RADIATION FIELD THAT PRODUCES LESS THAN 15KCPM (APPROX. 1% FULL SCALE) TO PREVENT INTERACTION WITH THE DEAD TIME ADJUSTMENT. SCINTILLATION TYPE PROBES CAN BE SET IN FIELDS THAT ARE SOMEWHAT HIGHER DUE TO THE LOWER DEAD TIME OF SCINTILLATION PROBES. HOWEVER SCINTILLATION PROBE SHOULD HAVE THE CC SET IN AS LOW A FIELD AS PRACTICAL.

Adjust the DOSE/COUNT switch to the DOSE POSITION.

Place the #1 probe in a calibrated radiation field that will produce less than 15kcpm (ABOUT 1% OF FULL SCALE).

Adjust P1, P2 & P3 until LCD indicates the correct radiation field

DEPRESS SW5 ONCE UNTIL "CAL" DISAPPEARS.

THIS COMPLETES THE INITIAL SETTING OF THE CALIBRATION CONSTANT.

ADJUSTING THE DEAD TIME FOR THE PROBES

GENERAL: The DEAD TIME adjustment is the calibration point for the HIGH END OF THE PROBE OPERATING RANGE. The adjustment is completed utilizing potentiometer P3. The DEAD TIME adjustment will become active when SW4 is adjusted to Position 5. P3 will become active when SW5 is depressed and "CAL" is displayed on the readout.

RATEMETER 1 DT ADJUSTMENT

Determine the full scale range for the PROBE 1

Be sure MAIN SELECTOR SWITCH is still in RATEMETER 1 position and DOSE/COUNT switch is in the DOSE POSITION

Place the Probe in a calibrated radiation field that is 70% - 90% of the probes NORMAL operating range.

Adjust SW4 to the Position #5. (The number that appears before depressing SW5 is the DT in micro seconds that is currently in the system). Depress SW5 "ONCE" until "CAL" is displayed on readout.

Adjust P3 until the LCD indicates the correct value for the radiation field.

Depress SW5 until "CAL" is not displayed on the readout. THIS SAVES THE DATA.

Adjust SW4 to the Position #0 (normal operating position).

A PANCAKE PROBE (ie. HP-265) THAT HAS A NORMAL OPERATING RANGE OF 0 – 200mR/hr would be tested as follows to verify the accuracy of the overall calibration.

Range 1 = 20% & 80% of 200 mR/hr
 Range 2 = 20% & 80% of 20 mR/hr
 Range 3 = 20% & 80% of 2 mR/hr
 Range 4 = 20% & 80% of 0.2 mR/hr

NOTE: AFTER THE CC & DT HAVE BEEN ADJUSTED THE RANGE READINGS SHOULD BE VERIFIED TO $\pm 10\%$ AT EACH READING CALCULATED FOR RANGE 1 – RANGE 4. IF THE MEASUREMENTS ARE NOT WITHIN $\pm 10\%$ OF THE CALCULATED CALIBRATION POINTS THE CC AND DT PROCESS WILL NEED TO BE REPEATED UNTIL THE CALIBRATION POINTS ARE WITHIN THE $\pm 10\%$ TOLERANCE.

ADJUSTING THE CALIBRATION CONSTANT & DEAD TIME FOR RATEMETER 2 PROBE

Adjusting the CALIBRATION CONSTANT & DEAD TIME for PROBE 2 requires the MAIN SELELCTOR SWITCH to be adjusted to the RATEMETER 2 POSITION.

Repeat all instructions for the RATEMETER 1 PROBE

ADJUSTING THE OVER RANGE ALARM

GENERAL: The OVER RANGE ALARM is utilized to make the person operating the survey meter aware that they have exceeded the normal operating limits of the survey meter and that the data is becoming inaccurate. The OVER RANGE ALARM is audible and visual. ALARM is indicated by the audio and LCD alarm pulsing approximately 1 once per second. The alarm will stop when the field at the detector returns to normal operating range. In this procedure P1 & P2 will utilized to make the adjustments. P2 acts as a COURSE adjustment and P1 will act as a FINE adjustment. **PROBE DOES NOT HAVE TO BE IN RADIATION FIELD FOR THIS ADJUSTMENT**

Adjust the MAIN SELECTOR switch to the input (RATEMETER 1 OR RATEMETER 2) that requires the OVERRANGE ALARM ADJUSTMENT.

Adjust SW4 to the Position #3. The number that appears will be the alarm setting that is currently established for the PROBE 1 input.

Depress SW5 (UNTIL "CAL" APPEARS) & Adjust P1 & P2 until the LCD indicates a reading that is 10% - 15% above the FULL SCALE range of the probe on the PROBE 1 input.

Depress SW5 until "CAL" disappears to save the data.

Adjust SW4 to the NORMAL OPERATION POSITION 0 (ZERO)

The survey meter is now ready for NORMAL OPERATION.

Adjust the MAIN SELECTOR SWITCH to the other RATEMETER POSITION AND REPEAT THIS PROCEDURE FOR THE PROBE.

ADJUSTING ALARM SETPOINTS

GENERAL: THE DSM-525 HAS AN AUDIBLE ALARM THAT CAN BE SET INDEPENDENTLY FOR RATEMETER DOSE, RATEMETER CPM & COUNTS. THE SAME CONTROLS SW4, SW5, P1 & P2 ARE UTILIZED TO MAKE THESE ADJUSTMENTS. ADJUSTING THE ALARM SETPOINT TO 0 (ZERO) DISABLES THE ALARM. TO TEMPORARILY DISABLE THE AUDIBLE ALARM WHEN IT IS ALARMING DEPRESS THE ZERO SWITCH MOMENTARILY AND AUDIBLE ALARM WILL BE DISABLED. VISUAL ALARM ON LCD WILL STILL OPERATE. ALARM WILL RETURN TO NORMAL OPERATION WHEN SIGNAL FALLS BELOW SETPOINT.

ALARM SETPOINT DOSE

Adjust the MAIN SELECTOR switch to either RATEMETER 1 or RATEMETER 2

Adjust the DOSE/COUNT switch to DOSE

Adjust SW4 to position 2. Depress SW5 until "CAL" appears.

Adjust P2 & P1 until the readout indicates the desired alarm setting

Depress SW5 until "CAL" disappears to save data

Return SW4 to the #0 (ZERO) POSITION FOR NORMAL OPERATION

To set the ALARM for the other PROBE repeat the procedure with the MAIN SELECTOR switch in the other RATEMETER position

ALARM SETPOINT CPM

Adjust the MAIN SELECTOR switch to either RATEMETER 1 or RATEMETER 2

Adjust the DOSE/COUNT switch to CPM

Adjust SW4 to Position #2 Depress SW5 until "CAL" appears.

Adjust P2 & P1 until the readout indicates the correct alarm setting

Depress SW5 until "CAL" disappears to save data.

Return SW4 to the #0 (ZERO) POSITION FOR NORMAL OPERATION

To set the ALARM for the other PROBE repeat the procedure with the MAIN SELECTOR switch in the other RATEMETER position

ALARM SETPOINT SCALER

Adjust the MAIN SELECTOR switch to SCALER 1 OR 2.

Adjust SW4 to position 2 Depress SW5 until CAL appears.

Adjust P2 & P1 until the readout indicates the correct alarm setting

Depress SW5 until CAL disappears to save data.

Return SW4 to the 0 (ZERO) POSITION FOR NORMAL OPERATION

To set the ALARM for the other position (#1 or #2) repeat the procedure with the MAIN SELECTOR switch in the other SCALER position.

TIMED COUNT

GENERAL: THE DSM-525 HAS A TIMED COUNT FUNCTION AND CAN BE SET INDEPENDENTLY FOR EACH PROBE. THE RANGE OF THE TIMED COUNT IS 0 – 2550 SECONDS IN 10 SECOND INCREMENTS. THE TIMED COUNT FUNCTION IS ONLY AVAILABLE FOR EACH PROBE IN THE COUNT POSITION OF THE MAIN SELECTOR SWITCH. THE SAME CONTROLS SW4, SW5, P1 & P2 ARE UTILIZED TO MAKE THAT ADJUSTMENTS. FOR THE TIMED COUNT FUNCTION.

ADJUST THE COUNT TIME

Adjust the MAIN SELECTOR SWITCH TO SCALER 1. Adjust SW4 to position 1. This displays the counting time in seconds currently in the system.

To set the count time to change COUNT time Depress SW5 until CAL appears.

Adjust P3 until readout indicates the correct counting time in seconds

Depress SW5 until CAL disappears to save the data.

To adjust a timed count for SCALER 2 probe repeat steps 1 - 5

OPERATION IN THE TIME COUNT MODE

Adjust the MAIN SELECTOR SWITCH to the SCALER position for SCALER 1 or SCALER 2 (EXTERNAL PROBE or INT PROBE)

If count time is unknown adjust SW4 to the #1 position and COUNT TIME in seconds for that probe will be displayed. (CAUTION) DO NOT DEPRESS SW5 OR TIME COULD BE CHANGED)

Return SW4 to the #0 position and instrument is ready for normal operation.

To start a time count cycle Depress the ZERO SWITCH on the front panel FOR AT LEAST 3 SECONDS TO START COUNT CYCLE.

When the ZERO switch is depressed the timed count cycle will begin and the word "COUNTING" will appear on the display. When the cycle is complete the "COUNTING" will disappear and the word "COUNT" will appear. This indicates the count cycle has been completed.

The total counts will remain on the display until the ZERO switch is depressed for at least 3 seconds or the instrument is turned OFF.

If the instrument remains ON a NEW count cycle can be started by DEPRESSING THE ZERO SWITCH on the front panel for at least 3 seconds.

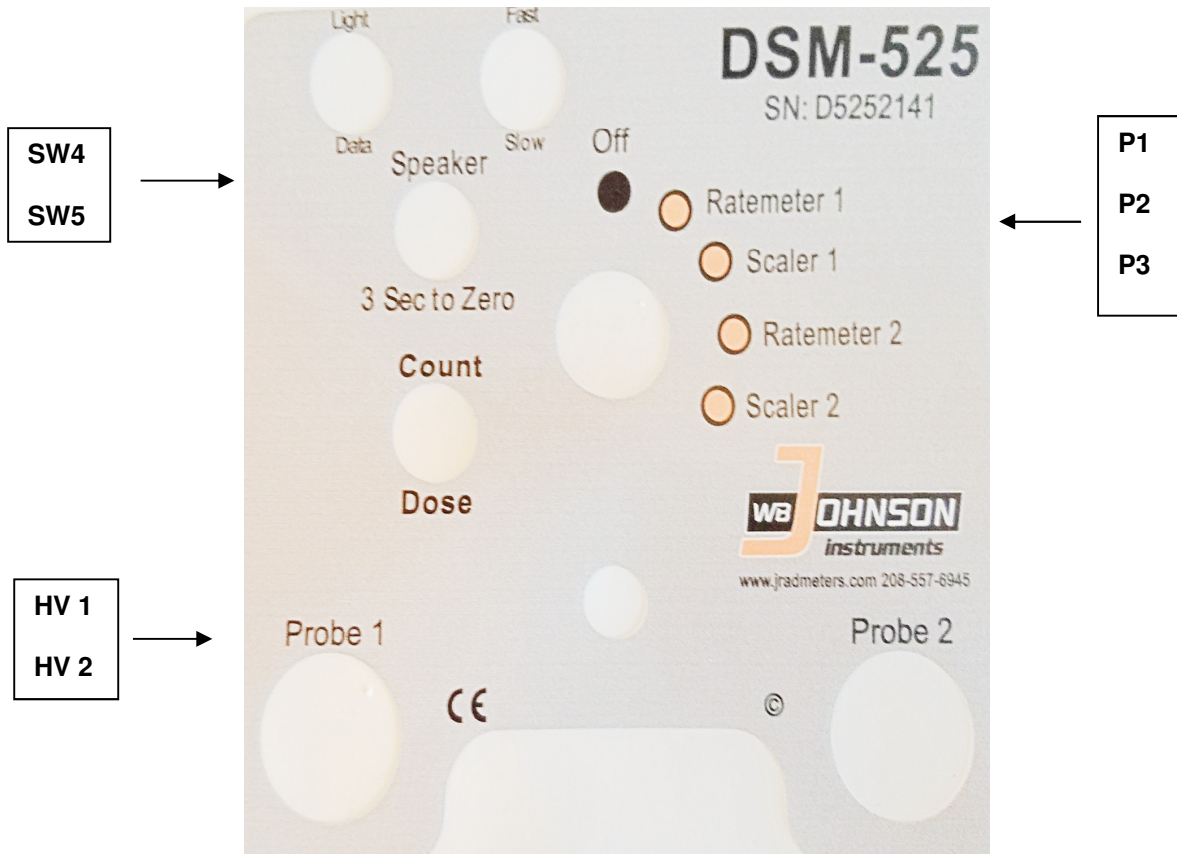

FIGURE 1
DSM-525 FRONT PANEL CONTROLS
& LOCATION OF MAJOR CAL CONTROLS

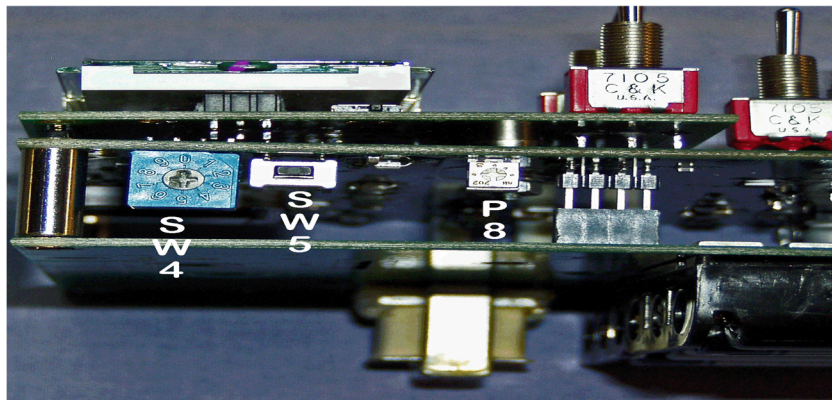

FIGURE 2

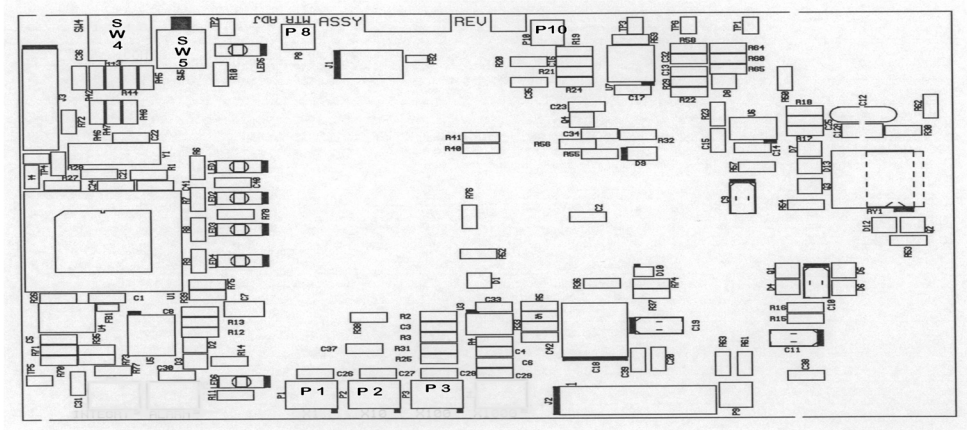

FIGURE 3
DSM-525 FRONT PANEL CONTROLS
P/N 12303 REV 6

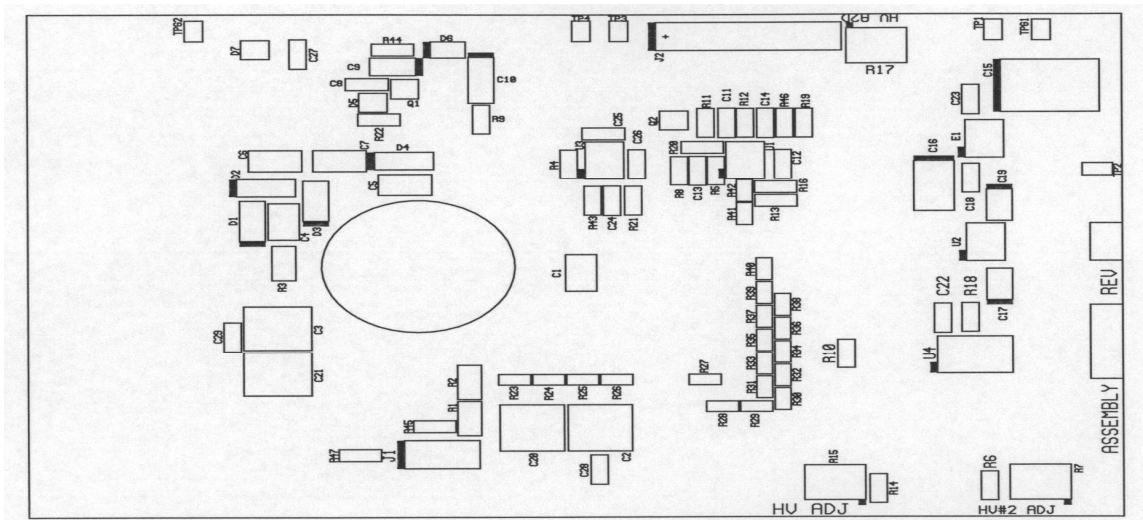

FIGURE 4
DSM-525 POWER SUPPLY AND MAJOR COMPONENTS
P/N 12291-1 REV 1

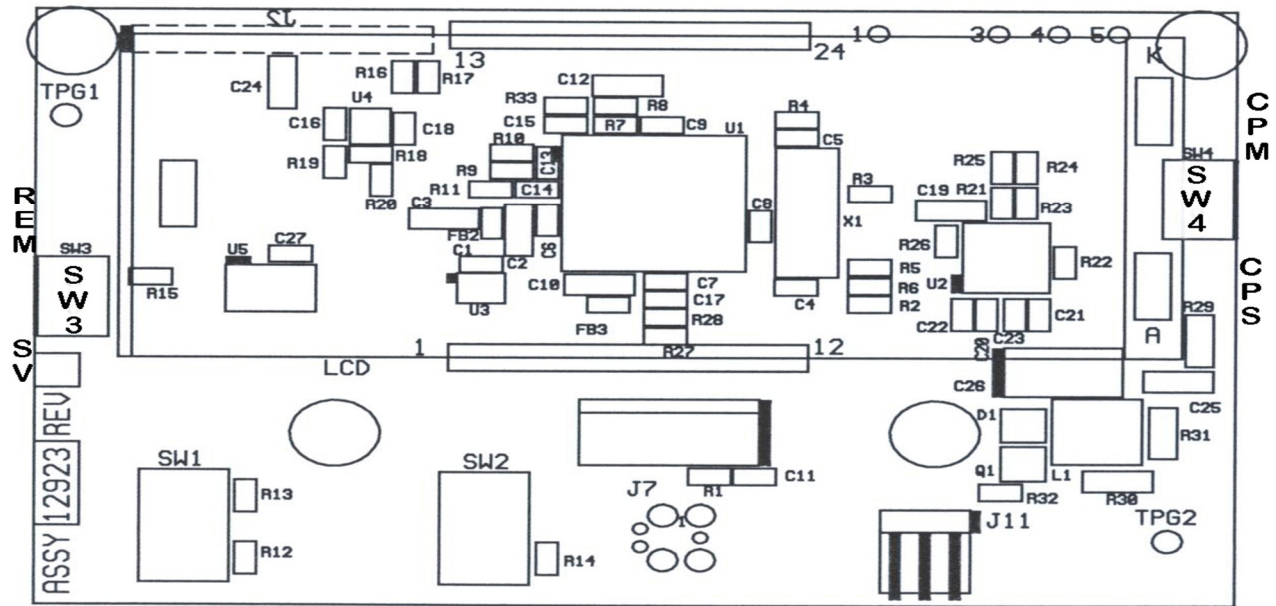

FIGURE 5
DSM-525 LCD DIGITAL PC BOARD COMPONENTS AND CONTROLS
P/N 12923

SECTION 6

TECHNICAL THEORY OF OPERATION

GENERAL THEORY

The DSM-525 utilizes the latest field proven, microprocessor circuitry to operate all of the GM and scintillation probes manufactured by Johnson. The instrument can function as a regular ratemeter without dead time compensation, regular ratemeter with dead time compensation, scaler with counting times from 10 – 2550 seconds in 10 second increments. The system changes ranges automatically and has separate non interacting controls for dose and dead time compensated cpm or cps calibration for each input. Other adjustments with internal controls are: HV, COUNT TIME, LCD REFRESH RATE, FAST TC & SLOW TIME CONSTANT. Operation in either the counts/minute or dose mode for each probe is switch selectable from the front panel. The electronic circuitry is located on 2 heavy duty industrial type printed circuit boards that are directly interconnected to improve reliability and durability. All of the internal power is provided by a highly regulated -5 vdc & +5 vdc ($\pm 0.5\%$) low temperature coefficient power supplies. A separate high stability higher voltage power supply is provided FOR EACH PROBE with a low temperature coefficient provides 300 - 1500 vdc ($\pm 1\%$) to operate probes with different HV requirements. A OVER RANGE ALARM is available for each probe that produces a beeping audible alarm when the usable range of the probe has been exceeded. Diagnostic circuitry constantly monitors the power supply, high voltage supply and GM detector and indicates out of tolerance operation by indicators on the LCD or by audible alert. The External probe is connected to the main electronics housing by a high quality coaxial cable with quick disconnect BNC connectors. A RS-232 data port is provided by a 9 pin sub-d connector. Data is available at the connector when the "DATA" switch located on the front panel is depressed.

DETECTOR SIGNAL – DIAGNOSTICS – CALIBRATION CONTROLS

A microprocessor meter operates much differently than an analog type meter. Most of the functions i.e. dead time correction, diagnostics etc. are provided by the microprocessor programming (software). The DSM-525 contains two micro-processors. One processor controls and manipulates the data from the probes and provides the HV and calibration support. The 2nd processor on the DISPLAY pc board controls the data to the display and provides the RS-232 signal to the 'DATA OUTPUT CONNECTOR'. Switch SW4 is an internal switch on the CPU that controls the CALIBRATION FUNCTIONS of the DSM-525. SW5 is a push button switch located by SW4 that is used to activate the calibration procedure selected and save the settings of the potentiometers utilized to calibrate each particular function. FIGURE 1 & 2 shows SW4 and SW5 and their position on the CPU pc board. Calibration of the ALL THE PARAMETERS IN THE SYSTEM is completed by utilizing SW4, SW5, P1, P2 & P3. SW4 is utilized to select the function that will be calibrated or set and P1, P2, & P3 are utilized to adjust the parameters. When a particular function has been set (calibrated) to the desired levels SW5 is depressed to save the readings on P1, P2 & P3. Each position on SW4 represents a function or parameter that is being adjusted. As a result of this system the potentiometers P1, P2 & P3 are utilized over and over again to adjust the parameters. When the calibration procedure has been completed SW4 IS ADJUSTED TO "0" ZERO POSITION FOR NORMAL OPERATION. FIGURE 2 SHOWS THE LOCATION OF SW4, SW5, P1, P2 & P3. FIGURE 3 SHOWS THE COMPONENT LAYOUT OF THE POWER SUPPLY PRINTED CIRCUIT BOARD AND THE LOCATION OF THE MAJOR COMPONENTS.

HIGH AND LOW VOLTAGE POWER SUPPLIES

Six "AA" size batteries provide the LOW VOLTAGE power for all of the DSM-525 circuitry. The batteries are connected to a positive power regulator on the POWER SUPPLY pc board designated E1. E1 converts the 9 vdc to a very stable +5 vdc. The output of E1 (+5 vdc) is connected to the circuitry requiring +5 vdc and the negative 5 vdc regulator U2. The output of U2 (-5 vdc) is connected to the circuitry requiring -5 vdc. Both power regulators (E1 & U2) have very good regulation $\pm 5\%$ and a low temperature coefficient. The HIGH VOLTAGE supply is comprised of a special high efficiency transformer with a feedback winding and oscillator circuitry to generate a low ripple, stable high voltage. The output of the transformer T1 is connected to a voltage doubler circuit comprised of D1-D4 & C3-C7. The output of the doublers circuit is filtered in a pi type filter and connected to the PROBE BNC through R1. R1 is also the load resistor for the detector circuit. The HV oscillator circuit through R4 constantly monitors the high voltage. R4 provides U1 a low voltage signal that represents the high voltage. Any change in the high voltage will result in an appropriate increase or decrease in the power Q1 & Q2 provide the high voltage transformer. This "feedback" is utilized to regulate the high voltage to approximately $\pm 1\%$. The power supply is designed with two high voltage outputs that can be independently adjusted between 300 – 1500 vdc. Figure 3 show the power supply pc board's major components and calibration controls

SECTION 7

PARTS LIST

PARTS LIST**DSM-525 LCD PC BOARD -- P/N 12472**

JOHNSON P/N	DESCRIPTION	REFERENCE	QUANTITY REQUIRED
12923-1	LCD DRIVE BRD REV-1		1
116200	I.C 4Kb FRAM SERIAL MEMORY		1
116199	I.C. 80 PIN FLASH MICRO CONTROLLER		1
105291	SWITCH ON-OFF-ON	SW1	1
107424	SWITCH TOGGLE	SW2	1
107591	TERMINAL STRIP 50 PIN	J7	6
108119	RESISTOR 100 OHM – 5%	R30,31	2
108392	RESISTOR 10 OHM – 5%	R29	1
109162	CAP. 10 PF – 50 V	C4, 5	2
109413	CAP. 100PF – 50 V	C11	1
110197	RESISTOR 47K 5%	R1	1
110199	RESISTOR 10K 5%	R9,11,12,13, R14,15	6
110201	RESISTOR 1K 5%	R7	1
110202	CAP 0.1 MF 16 V 10%	C1,6,7,8,9,13 C14,15,18,20 C21,22,23,27	14
110226	CAP 47 MF 20V 10%	C26	1
110387	JUMPER 0 OHM	R10	1
110653	RESISTOR 100 OHM 5%	R33	1
110754	RESISTOR 100K 5%	R2,3,4,5,6,21 R22,23,24,25 R26,27,28,32	14
111143	TERM STRIP 50 PIN	J2	10
112729	TRANS. 60V 500ma	Q1	1
114115	FERRITE CHIP 2.5 A- 120 OHM	FB2, FB3	2
114206	CRYSTAL 10 MHZ (SMT)	X1	1
114293	SLIDE SWITCH	SW3,SW4	2
114939	DUAL SCHOTTKY DIODE 30V	D1	1
116001	CAP 2.2µF 25V 10%	C2,3,10,12,19 C24,25	7
116014	HEADER MALE PIN3 POS	J11	1
116020	I.C.OP AMP AD8628	U4	1
116196	LCD DISPLAY JOHNSON	LCD	1
116197	TERM STRIP LOW PROF. 50 PIN		33
116198	I.C. 3V – 5.5 RS-232 DRIVER/REC	U2	1

DSM-525 LOGIC BOARD -- P/N 12472

JOHNSON P/N	DESCRIPTION	REFERENCE	QUANTITY REQUIRED
105291	SWITCH ON-OFF-ON	SW1	1
107424	SWITCH TOGGLE	SW2	1
108433	6-32 X 5/8" STANDOFF SWAGE		2
113013	RF CONN GOLD CONTACT	PROBE 1,2	2
100201	RESISTOR 2K 5%	R28	1
100234	RESISTOR 2.2K 5%	R6,R76	2
100242	CAP .01MF 50 V 20%	C32,41	2
100703	RESISTOR 20K 5%	R17	1
100711	RESISTOR 15K 5%	R13	1
101278	SWITCH RIGHT ANGLE PUSH BUTTON	SW5	1
103742	SWITCH 2 POL 6 POS	SW3	1
105462	SPACER #5 X 3/16"		2

107479	SWITCH RIGHT ANGLE BCD	SW4	1
108030	I.C ON TIME PROG 8 BIT	U1	1
108117	RESISTOR 10K 5%	R1,14,15,16,20,21,24 R26,47,59,60	11
108118	RESISTOR 4.7K 5%	R23	1
108119	RESISTOR 100 OHM 5%	R50	1
108123	DIODE 100V	D2,3,12,13	4
108128	CAP .22MF 50V 10%	C7	1
108217	RESISTOR 220K 5%	R4	1
108349	RESISTOR 1K 5%	R29,52,53,54	4
108350	RESISTOR 1MEG 5%	R22,31,33,55,56,58	6
108358	CAP 0.1 MF 50 V 20%	C1,3,5,8,14,15,16,17, C20,23,24,25,26,27,28, C29,30,31,33,34,35,36 C37,38,39,40,42	27
108385	CAP 10MF 25V 10%	C9,10,11,19	4
108433	6-32X5/8 SWAG STANDOFF		2
108661	TRAN BIPOLAR NPN 40V	Q1,2,3	3
108667	CAP 1MF 16V 10%	C4,6	2
108791	RESISTOR 82K 5%	R2	1
108793	RESISTOR 56 OHM	R19	1
108847	ECONORESET	U4	1
108865	DUAL DIODE	D7	1
109127	RESISTOR 560K 5%	R18	1
109134	LP339M I.C.	U7	1
109150	RESISTOR 1.6K 5%	R6,7,8,9,10,11	6
109156	I.C	U3	1
109262	RESISTOR 10 MEG 5%	R27	1
109263	CAP 22PF 50 V 5%	C21,22,25	3
109641	CAP 470 PF 16 V 10%	C18	1
109930	52 PIN SOCKET	U1	1
110162	FERRITE 1000 OHM 400ma	FB1,FB2	2
110634	RESISTOR 91K 5%	R64	1
111037	CAP 100PF 1KV 10%	C12A	1
111888	DIODE SCHOTTKY 30V 30 ma	D1,4,6,7,8,	5
112341	RESISTOR 249K 1%	R25,51	2
112426	RESISTOR 120 OHM 5%	R57	1
112452	SOCKET 10 PIN	J3	1

DSM-525 LOGIC BOARD -- P/N 12472

JOHNSON P/N	DESCRIPTION	REFERENCE	QUANTITY REQUIRED
112948	2.5 X2MM RED LIGHT	LED 1,2,3,4,5,6	6
112995	JUMPER 0 OHMS	J3	1
112997	TEST POINTS	TP1,2,3,4,5,	5
113013	RF CONN GOLD CONTACT	PROBE 1	1
114058	I.C. 3 mhz OP AMP	U6	1
114074	RECTIFIER 12V 4.3 AMP	Q4	1
114185	2 FORM C 5 V 2 COIL LATCH RELAY	RY1	1
114186	8 mhz 18PF FUND	Y1	1
114187	10 PIN CONNECTOR	J2	1
114188	4 PIN CONNECTOR	J1	1
114189	15 V BUZZER 3kc	SPK 1	1
113191	2K POT 1 TURN	P8	1
115253	DIODE SCHOTTKY	D10	1
116203	1K POT 1TURN	P10	1
116278	50K 12TURN POT	P1,2,3,4,5,6	6

12929-1	PC BOARD W/LCD SUP	1
9021-3	SPEAKER GASKET DIE #518	1
9077-4	ROTARY SWITCH MOD 103742	1

DSM-525 POWER SUPPLY BOARD -- P/N 12291

JOHNSON P/N	DESCRIPTION	REFERENCE	QUANTITY REQUIRED
100231	51K 1/8W 1206 PKG	R43	1
100242	0.01MF 50V 1206 PKG	C13	1
100703	20K 1/8W 1206 PKG	R46	1
102804	4-40 KEPNUT	B1, 2	4
104539	W/MTG STRAP TRANSFORMER	T1	1
106712	4-40X 2/8 UNDERCUT	B1, 2	4
108117	10K 1/8W 1206 PKG	R16, 19, 20	3
108118	4.7 1/8W 1206 PKG	R11	1
108123	100 VDC 200 MW DIODE	D5, 7	2
108303	3AA PC MOUNT BL. BAT. HOLDER	B1, 2	2
108349	1K 1/8 1206 PKG	R4, 21	2
108350	1M 1/8W 1206 PKG	R8	1
108353	1.5K 1/8W 1206 PKG	R9	1
108358	0.1 50V 1206P	C8, 11, 12, 14, 18, 22, 23, 25-27	10
108661	NPN 40V SOT-23	Q2	1
108667	1MF 16V 1206 PKG	C24	1
108829	47K 1/8W 1206 PKG	R18	1
109011	SOT-23 60V 150A PNP BIPOLAR	Q1	1
109133	5V REGULATOR	E1	1
109156	MC33172D I.C.	U1, 3	2
109163	110K 1/8W 1206 PKG	R 6, 14	2
109641	470MF 16V	C15	1
109896	2.4K 1/8 W 1206	R12	1
110481	1MF 50V 6032 PKG TANT.	C10	1
110656	10MF 16V 3528 PKG. TANT	C9, 17, 19	3
110761	1A 600V RECTIFIER DIODE	D1-4	4
110824	200 OHM 1/8 1206 PKG	R22	1
111128	100 MF 20V 7343 PKG ROHS COMP	C16	1
111180	1M 1/2 W 2010 PKG	R1-3	1
112074	CMOS VOLTAGE CONVERTER	U2	1
112118	100PF 3000V 1808 PKG	C1	1
112298	0.027 MF 2KV 2225 PKG	C2, 3, 20, 21	4
112341	249K 1/8 1206 PKG	R13	1
112695	0.001MF 1KV 1808 PKG.	C4-7	4
112995	0 OHM JUMPER 1206 PKG	R44	1
112997	MINIATURE TEST POINTS	TPG1, 2 TP 1-4	6
113143	2.7M 1/8 W 1206 PKG.	R45, 47	2
114190	50K 4MM SQ. SINGLE TURN TRIMMING	R7, 15, 17	3
114193	10 PIN .25" SQ SINGLE SOCKET	J2	1
114194	4 PIN .025" SQ SINGLE SOCKET	J1	1
114220	22M 1/10W 0805 PKG	R23-42	20
114737	MUX/DMUX TRI 2CH ANLG. 16 SOTC 1.C.	U4	1

SECTION 8

SCHEMATICS

CPU BOARD

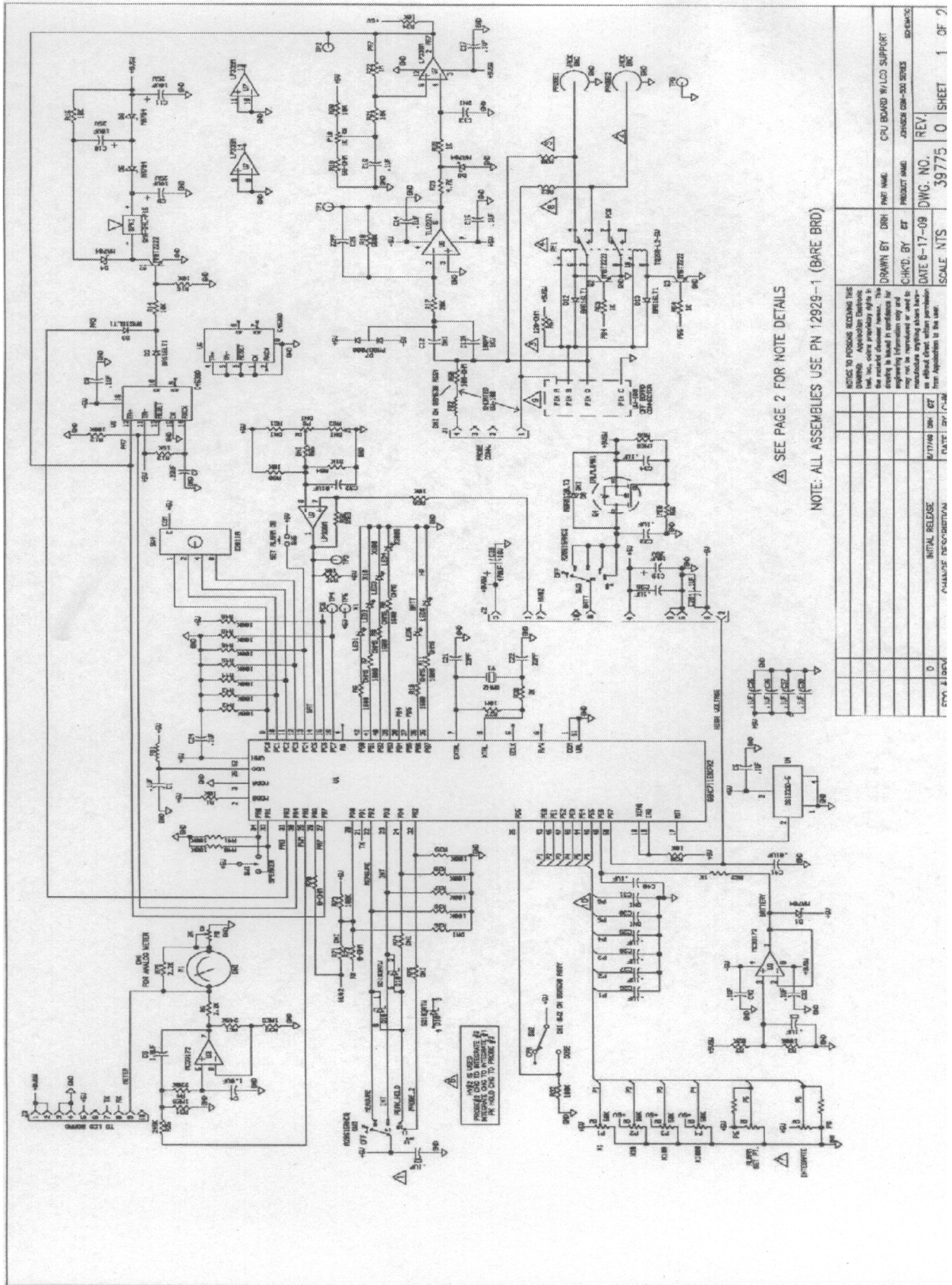

SEE PAGE 2 FOR NOTE DETAILS

NOTE: ALL ASSEMBLIES USE PN 12928-1 (BARE BRD)

DATE	0	INITIAL RELEASE	0	DATE	8/17/08	BY	BT
SCALE	1:1	NTS	39775	DWG. NO.	0	REV	1
PROJECT NAME	JANISER DSM-525 SERIES		SCALE	1:1		SHEET	1
PRODUCT NAME	CPU BOARD W/LCD SUPPORT		SCALE	1:1		SHEET	1
PROJECT NAME	JANISER DSM-525 SERIES		SCALE	1:1		SHEET	1
PROJECT NAME	JANISER DSM-525 SERIES		SCALE	1:1		SHEET	1
PROJECT NAME	JANISER DSM-525 SERIES		SCALE	1:1		SHEET	1
PROJECT NAME	JANISER DSM-525 SERIES		SCALE	1:1		SHEET	1
PROJECT NAME	JANISER DSM-525 SERIES		SCALE	1:1		SHEET	1
PROJECT NAME	JANISER DSM-525 SERIES		SCALE	1:1		SHEET	1
PROJECT NAME	JANISER DSM-525 SERIES		SCALE	1:1		SHEET	1

LCD BOARD

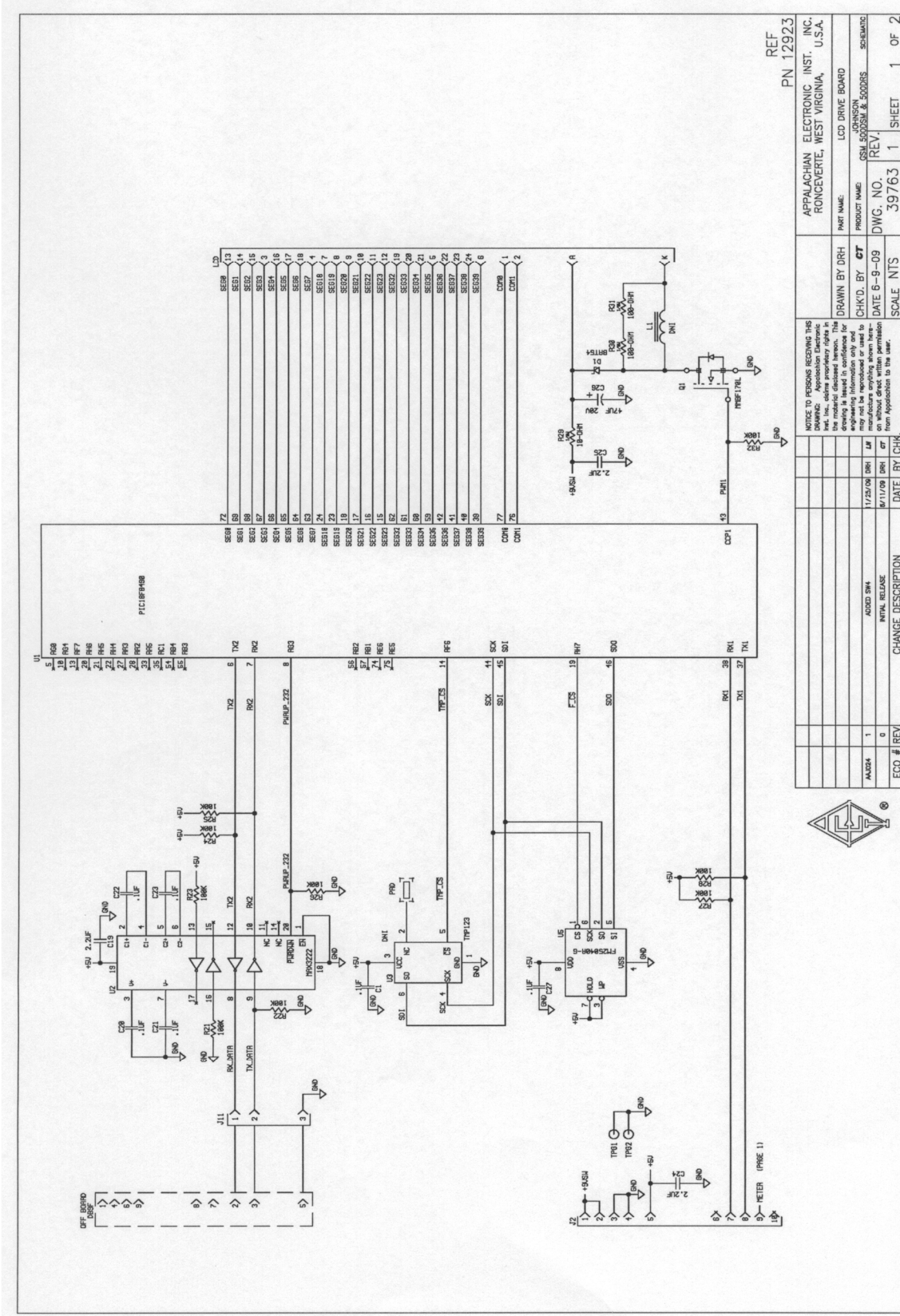

REF PN 12923
 APPALACHIAN ELECTRONIC INST. INC.
 RONCEVERTE, WEST VIRGINIA, U.S.A.

PRODUCT NAME: LCD DRIVE BOARD
 DRAWN BY DRH
 CHK'D. BY GT
 DATE 6-9-09
 DWG. NO. 39763
 REV. 1
 SCALE NTS
 SHEET 1 OF 2
 #MASTER*

NOTICE TO PERSONS RECEIVING THIS DRAWING: Appalachian Electronic Instrumentation, Inc. is not responsible for the reproduction of this drawing in whole or in part without the written consent of Appalachian Electronic Instrumentation, Inc. The drawing is issued in confidence for the use of the purchaser and its manufacture anything shown hereon may not be reproduced or used for any other purpose without the written permission of Appalachian Electronic Instrumentation, Inc.

ECO #	REV	DATE	BY	CHK	CHANGE DESCRIPTION
A0004	1	11/20/06	DRH	JM	ADD SW4
	0	01/17/09	DRH	GT	INITIAL RELEASE

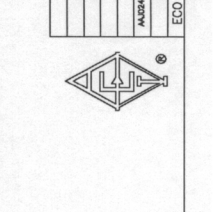

POWER SUPPLY BOARD

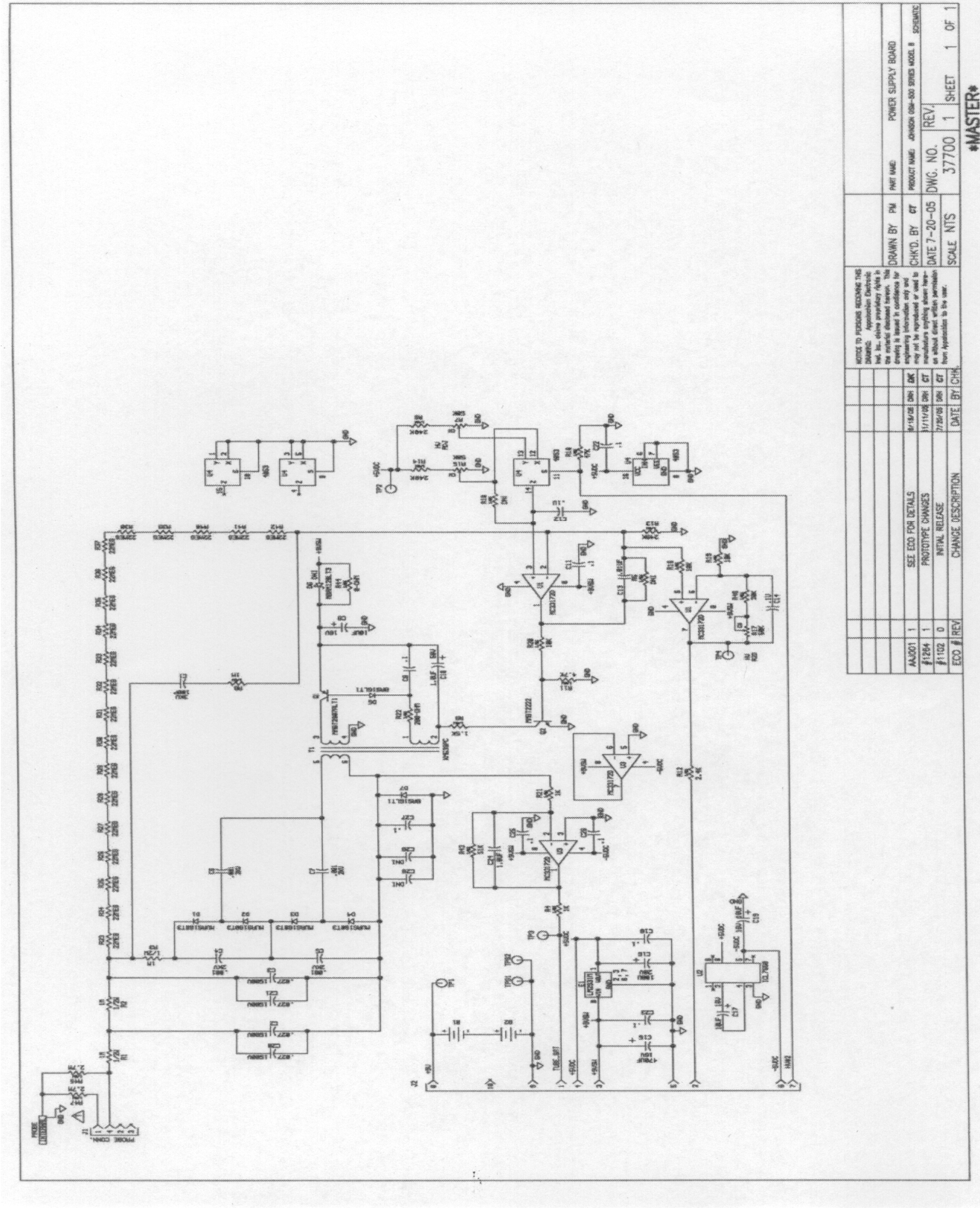

DRAWN BY		PM	PART NAME		POWER SUPPLY BOARD
CHKD. BY		GT	PRODUCT NAME		JOHNSON 684-800 SERIES MODE II SCHEMATIC
DATE		7-20-05	DWG. NO.		REV. 1
SCALE		NTS	37700		1 SHEET 1 OF 1
ECCO #		REV	CHANGE DESCRIPTION		DATE BY/CHK
44-001	1		SEE ECCO FOR DETAILS		10/14/02 SHN DK
#1284	1		PROTOTYPE CHANGES		1/11/03 SHN GT
#1102	0		INITIAL RELEASE		7/20/05 SHN GT

#MASTER*