



White Paper

Berkeley Nucleonics 675 / 676

AWGs & AFGs for Wireless and RF Devices





Introduction

In the World of Radio Communications, signals are rapidly converting to be all digital. This trend is mainly due to the better spectral efficiency that digital signals have compared to the analog ones. Signals central frequencies, spectral density, and bands are increasing to satisfy the growing demand of users; thus, devices are becoming more complex and critical in every operation they are requested to address.

Nevertheless, there are precise standards that must be met to market the product we are developing. This requires a full characterization of components, which, in most cases, are quite different from each other and producing specific test equipment for a single device to test is becoming too expensive and it is not feasible.

Here, the modern state of art Arbitrary Waveform and Function Generators can overcome that problem, providing flexibility that has never been seen before, giving engineers a powerful instrument to test a big variety of devices and appliances along with speeding up test phases and reducing time-to-market.

In this paper, we will look at the latest Berkeley Nucleonics advanced AWGs & AFGs and their ability to produce a big variety of signals required nowadays to stimulate almost any kind of electronic device to look at their response and validate their behavior, or find limits and error situations.

Special attention will be given to modern signal processing and transmission methods like base-band, Intermediate Frequency and Radio Frequency, or Ultra-Wide Band formats, like Spread Spectrum, which is a basic feature of WIFI and WiMAX transceivers and how our brand new Waveform Generators can accomplish the challenge of producing such a big variety of complex, fast signals and be the core of every testing toolset.

Wireless Data Transceiving

To transmit and receive information without using a cable, an electromagnetic field can propagate from one antenna to another and carry information on it. However, the environment in which it passes through can be very noisy and significantly alter the transmitted waveform, and consequently, the data included in it.

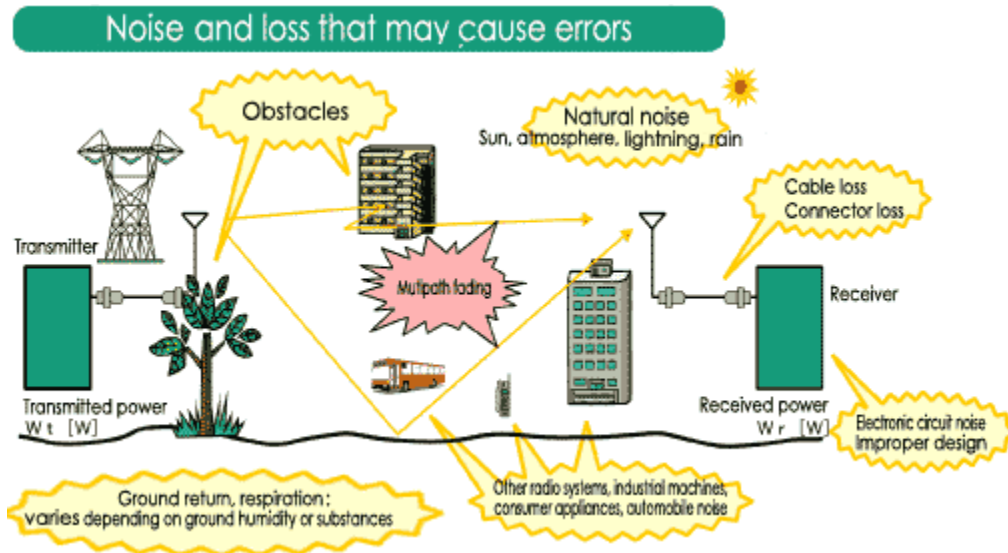

Many problems affect wireless communication like signal attenuation, distortions, inter-channel interference, and especially, in indoor situations or cities with high building density and multipath fading across the transmitted bandwidth.

To cope with these problems, many solutions have been introduced in modulation techniques, like spread spectrum over a bigger bandwidth and digital modulations with high symbol rates.

These waveforms are really complex and reproducing them with an instrument can be challenging, often times requiring device-specific test equipment, increasing costs and time-to-market.

In recent times a new instrument category is taking shape in this area.

These are called **Arbitrary Function Generators (AFG)** and **Arbitrary Waveform Generators (AWG)**.

Their main ability is to be able to create a large amount of waveforms by directly synthesizing them (AFG) or by using memory to store every sample value and then reproduce it at selectable output clock rates, even by looping, jumping, and sequencing a portion of them, using an acquisition instrument to create those samples or by directly building it with a dedicated tool application.

Why Digital Over Analog?

Analog modulations, like Amplitude, Frequency, or Phase Modulation (AM, FM, PM) have been widely used in the past. Since modulation and demodulation operations of these techniques are pretty simple and low cost (just think to AM which can be demodulated simply using a diode, a capacitor, and a resistor).

All of them are made by simply modulating a carrier signal with an analog one which contains the information to transmit and vary, respectively, the amplitude, the frequency, or the phase of the carrier (usually the phase of the carrier has a higher frequency than the modulating one).

However, since there is no encoding on transmitted signals, the only way to achieve a higher Signal-to-Noise ratio (SNR) is to increase the emitted power of the transmitter, modulate over a bigger bandwidth, and use high directionality and larger antennas. Every one of these has some problems: increasing the transmitted power is not always feasible, because electronic circuits have an increasing complexity compared to the power they have to manage; they become larger and need to be cooled.

Since channel count demand is increasing, to allocate every application that needs a RF link, a strict regulation assigns the maximum bandwidth that can be used.

On the last point, bigger antennas require massive structures to keep them in their position (they are usually also placed at high height from the ground) and directive ones do not allow broadcasting a signal at the same power in every direction.

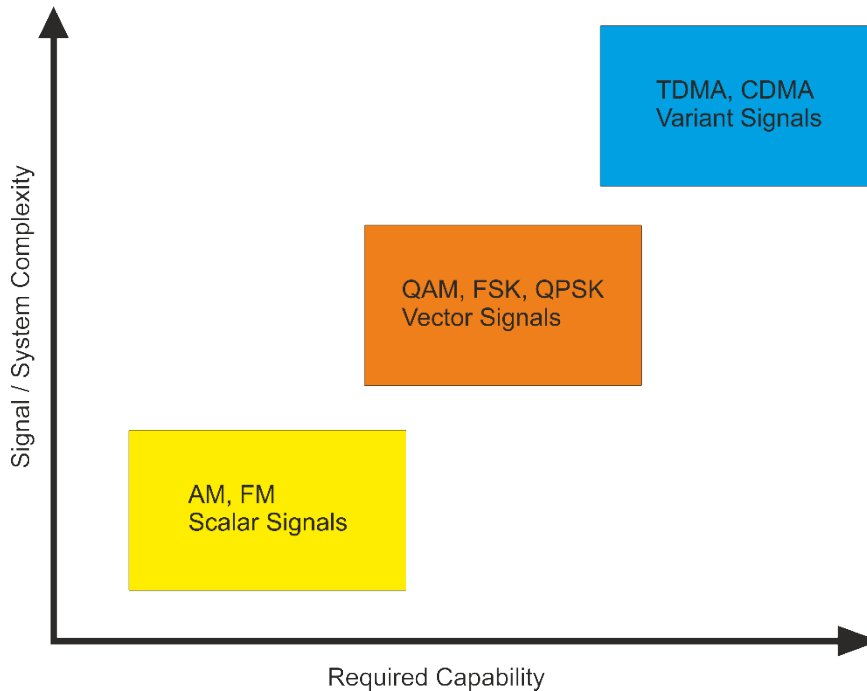

These reasons and the increasing spread of digital devices, summed to the fact that, nowadays, processing digital circuitry costs have decreased, caused an evolution in digital modulation techniques. This allows applications to gain a better SNR, more spectral efficiency, and also some multiplexing modes not possible with analog modulation (like Code Division Multiple Access or CDMA).

It is clear now that having an instrument capable of generating such a big family of waveforms, with one (or more) modulating signals and often also one or more carriers, adding some noise that might be caused by environment noise, propagating interferences, demodulation, and timing mismatches, helps to save a big amount of development funds and time.

A Tour into Digital Modulation

To transmit information “over the air”, splitting the common communication medium to allow different non-interfering data flows, we need to modulate a carrier (usually in radio or microwave band) with another signal (characterized by lower frequency with respect to the carrier) which contains the real content we are sending.

Both carrier and data signal can be either analog or digital and the choice depends on many factors. Most used rely on an analog carrier meanwhile, for the aforementioned reasons, nowadays it is common to have digital modulation. This consists of altering one carrier’s parameters (which can be amplitude, phase, or frequency) using one or more symbols, represented by bits.

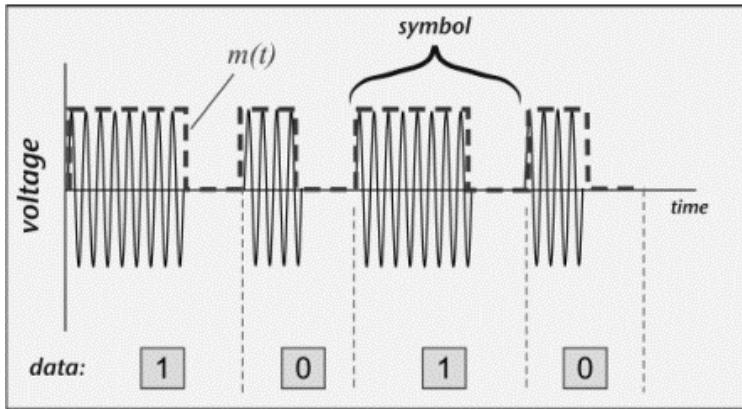

Figure 1: OOK Modulation

To understand what this means, let's take a look at the simplest digital modulation: the On-Off Keying (OOK), a simple form of Amplitude Shift Keying with two levels (2-ASK); this consists of two symbols (i.e., 0 or 1) digital amplitude modulation, so it is like switching on and off the carrier. This way, the presence of the carrier is coded into a "1" and the absence of it represents a "0". Those two bits anyway could vary even one of the other two carrier's parameters: by varying frequency we will obtain a two-levels frequency shift keying (2-FSK) or a 2-PSK (also called BPSK) if we are changing carrier's phase on two levels.

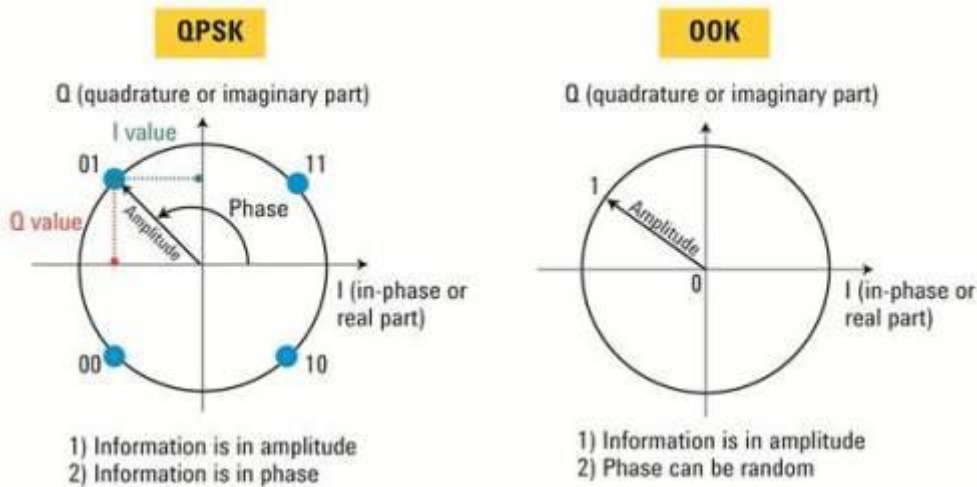

Figure 2: Polar Display

It is not over though. The number of symbols we use to encode the transmission affect both *energy efficiency* (how powerful the signal must be to be correctly decode at the

receiver) and *spectral efficiency* (how wide the bandwidth is in order to achieve a specific bit-rate) of the communication.

This represents a tradeoff, because the more the first one grows, the more the second one decreases. Since the ability to capture and correctly read a signal with low signal-to-noise ratio is increasing, it is possible to lessen E_b/N_0 ratio in favor of spectral efficiency.

Because of it, transmitted waveform's complexity is becoming higher and the bigger bps/Hz ratio can be reproduced only by a fast and flexible instrument.

Another modulation method that has gained space in modern communication systems is a special kind of amplitude modulation, also called Quadrature AM (QAM).

This one works by modulating, with the same information, two out-of-phase carriers instead of one and mixing together those two channels. These are called I/Q channels, because one is in-phase and the other one is in quadrature with the first one (i.e., 90 degrees of delay), so the "I" channel carrier is a cosine and the "Q" channel carrier is a sine.

Summing them together, the I/Q relative amplitude can place a phasor vector on a discrete number of points onto a constellation, in which any point represents a transmitted symbol. By using a number of symbols in a power of two, we ascertain the number of bits to represent each symbol, therefore the number of bits each symbol transports, is the base two logarithm of the total number of symbols. Not only amplitude but also frequency and phase can be put on a quadrature modulation to use coherent demodulation to better recover symbols and TX/RX synch.

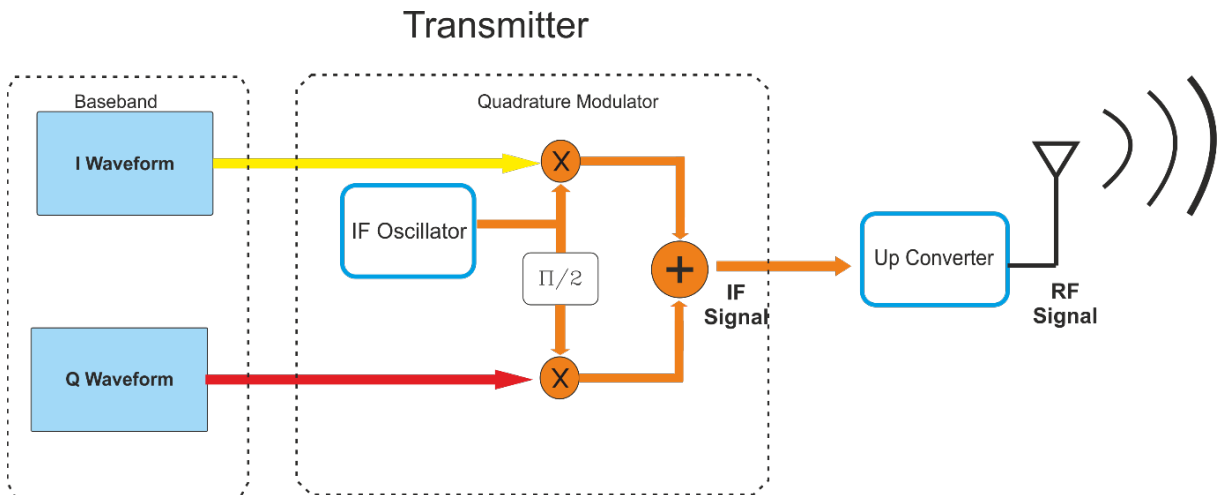

Figure 3: IQ Transmitter

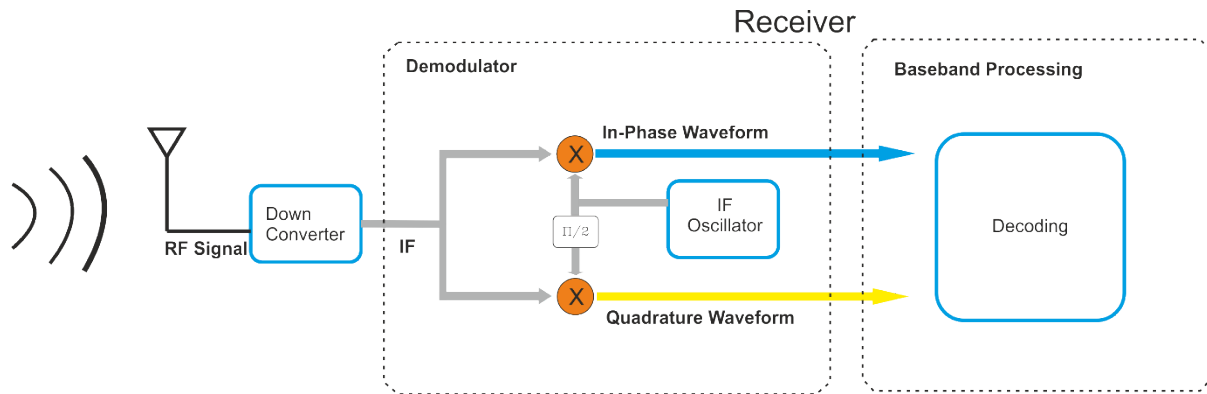

Figure 4: IQ Receiver

Also, widely used is QPSK, which has a good spectral and power efficiency. In modern systems, it is easy to see the use of high complex waveforms, which can be also a time-combination of the previous one, as it happens in Wireless LAN communication, in which the modulation is varied to a better use of spectrum if Signal-to-Noise ratio is enough in order to obtain a big data-rate without occupying all the available bandwidth or using a more power efficient technique, reducing bit-rate, if the used channel is noisy.

Other systems as in Bluetooth technology or in already mentioned WLAN, can jump from one carrier frequency to another to spread the spectrum and obtain less power emission over a single band. The law limits the effective radiated power of wireless devices, so spreading the same power over a wider bandwidth will decrease the average emitted power without dropping the S/N Ratio.

To better satisfy the increasing traffic requests, some of them also use Code Division Multiple Access (CDMA) in addition to Frequency and Time Multiplexing (respectively, FDMA and TDMA), which is a method that codes every symbol over a longer symbols' sequence which can then be separated from the others at the receiver. Even though they are travelling on the same carrier at the same time but require a higher bandwidth and faster modulators and demodulators (actually, a CDMA that uses codes made by 16 symbols, needs a bandwidth 16 times wider than without CDMA in order to keep the same effective bit-rate).

Another thing to consider is that we are still talking about digital signals. Also the bit's shape has important consequences on the final global performance of communication systems.

Since the final signal's spectrum is the Fourier transform of the bits' shape, if we are using something near a rectangle (as a bit is usually represented, not possible to exactly do a rectangle because it requires an infinite bandwidth), the spectrum will look like a sinc, which spreads power on a too wide bandwidth and will bring interference with the near frequency channels.

A widely used filtering is called raised-cosine, which shape looks like a smoothed rectangle. The smoothness factor is represented by a parameter called alpha, which is directly proportional with the bandwidth of the final signal but also drive to overshoot and alteration of the original symbols' constellation.

Seeing how many complex operations are made to create a signal with the higher possible efficiency in terms of spectrum usage and power, it should now be clear that to test all those devices requires building a full custom instrumentation.

By using our AWG, it is possible to test any signal with a spectral component up to more than 1GHz while keeping a Voltage resolution of 14 bits, which means that the vertical precision is higher than 1 over 16000 of the full voltage swing.

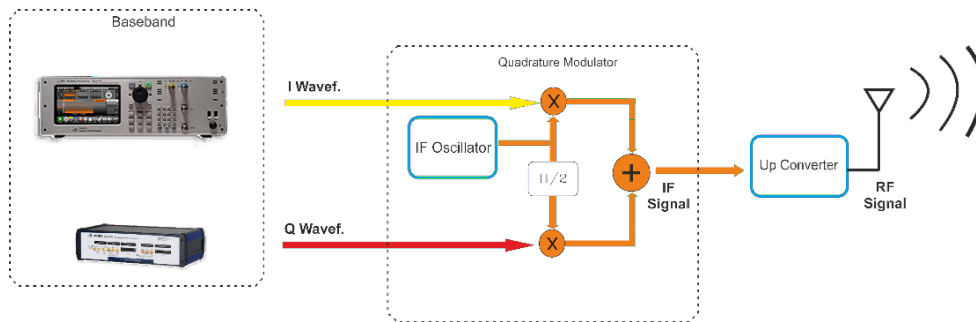

Figure 5: AWG for Baseband signals (TX): Model 676 and AT-AWG-GS

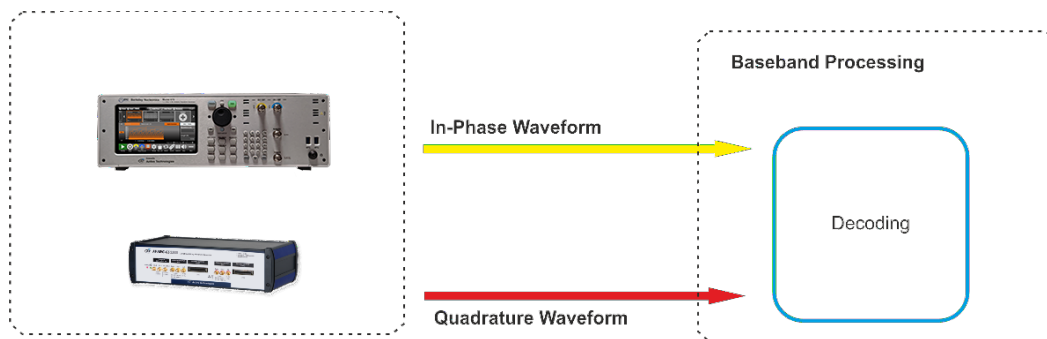

Figure 6: AWG for Baseband signals (RX): Model 676 and AT-AWG-GS

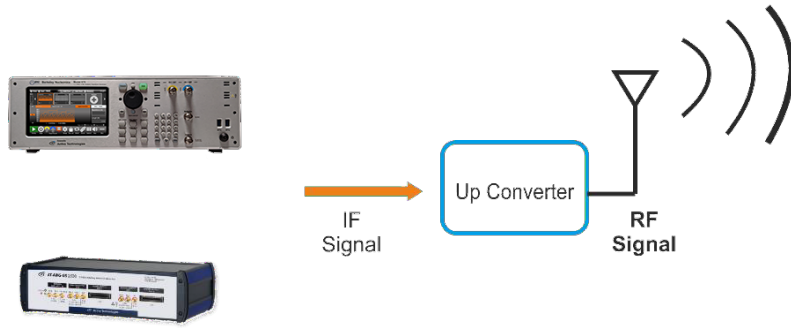

Figure 7: AWG for IF signals (TX): Model 676 and AT-AWG-GS

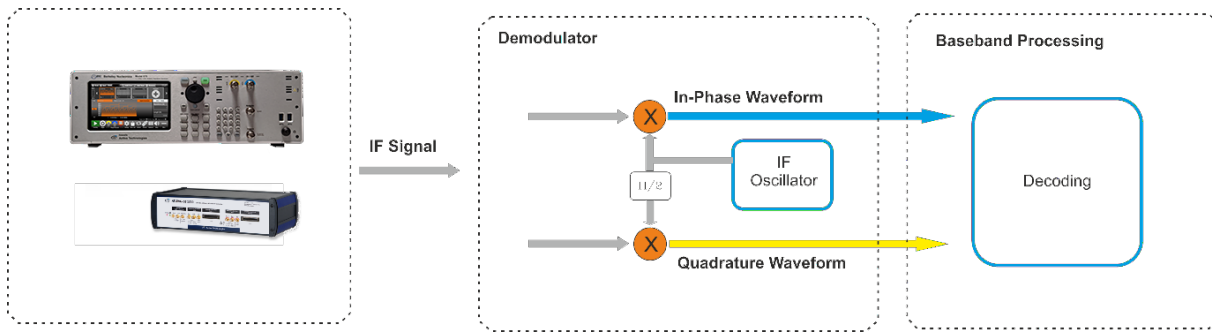

Figure 8: AWG for IF signals (RX)

Next, families already in progress will push this limit even beyond, by being equipped with a clock that can go up to 10, 20, and 50 GHz, which will allow the user to work also with last Ultra-Wide Bandwidth techniques, which are becoming popular for being really reliable against multipath problems and can effectively work good in indoor environments while keeping a high DAC resolution and the possibility to oversample the waveform to reproduce it with high time precision too, thanks to high clock rates and memory space (actually up to 64M sample per channel and bigger for the next products generation).

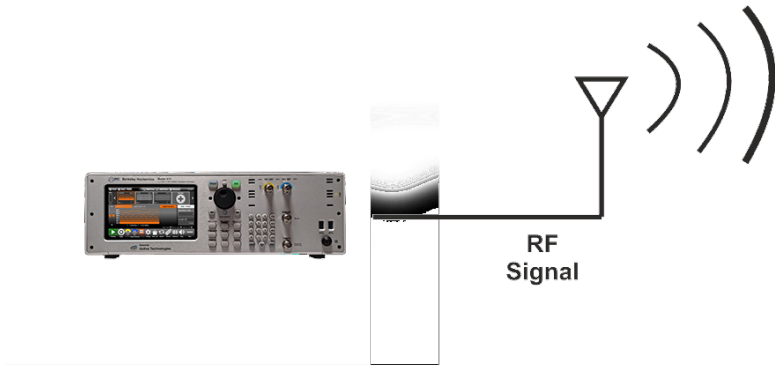

Figure 9: AWG for RF Signals (TX): Model 676

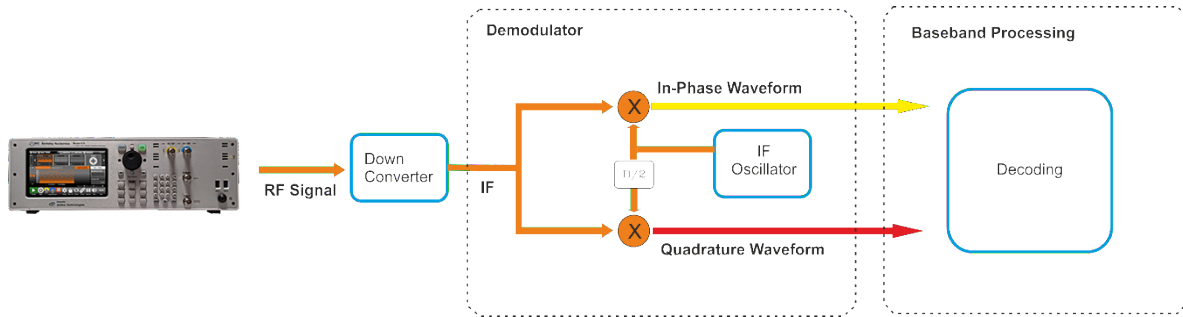

Figure 10: AWG for RF Signals (RX): Model 676

Common Implementations of Digital Modulation

Prompted by the digital revolution taking place in last years and helped by the decreasing cost of Digital Signal Processing (DSPs) and FPGAs hardware, engineers started to develop Software Defined Radio implementation, which uses Digital Sampling and Filters (like FIR and IIR, Finite and Infinite Input Response filters) to build almost any kind of Wireless Device.

Nowadays, these techniques are used in every application's field, from consumer products to defense purposes.

Besides the already mentioned WLAN (formerly known as 802.11) and Bluetooth (used for Wireless PAN, which belongs to 802.15 IEEE standard), special attention must be given to Metropolitan Networks like Mobile Phones Communications, which rely on digital modulations since earlier versions like GSM (where the "G" stays for Gaussian, suggesting that the pulse shaping filter has Gaussian-like spectrum response) to modern implementations like HSDPA and LTE (also called 4G network) which uses CDMA and DSSS Quadrature Phase and Amplitude Modulations

Modulation	Application
MSK, GMSK	GSM, CDPD
BPSK	Deep space telemetry, cable modems
QPSK, $\pi/4$ DQPSK	Satellite, CDMA, NADC, TETRA, PHS, PDC, LMDS, DVB-S, cable (return path), cable modems, TFTS
OQPSK	CDMA, satellite
FSK, GFSK	DECT, paging, RAM mobile data, AMPS, CT2, ERMES, land mobile, public safety
8, 16 VSB	North American digital TV (ATV), broadcast, cable
8PSK	Satellite, aircraft, telemetry pilots for monitoring broadband video systems
16 QAM	Microwave digital radio, modems, DVB-C
32 QAM	Terrestrial microwave
64 QAM	DVB-C, modems, broadband set top boxes, MMDS, DVB-T
256 QAM	Modems, DVB-C (Europe), Digital Video (US), DVB-T2

Figure 11: Digital Modulation

In most countries, Television and Radio OTA transmissions are also turning into digital modulations to take advantage of channel coding to be more reliable against noise and data compression to improve the usage of their dedicated spectrum sections and allocate all increasing users requesting to access it; noteworthy are DVB (both terrestrial and satellite television streams use digital modulations) and DAB (Digital Audio Broadcasting). Another critical use of these techniques is for defense purposes, not just for communications, like TETRA, a standard mostly used for professional communications by police, firefighters, and military forces, which also allows end-to-end encryption and multicast half-duplex transmissions and use a particular type of Differential Quadrature PSK called pi/4, because constellations are not orthogonal but with a 45° skew.

Also, in Radio Detection and Ranging (RADAR) digital-based approaches are used to improve range and accuracy (these aspects will be analyzed in the next primer).

The following table gives an overview of our AWGs characteristics to better explain their capabilities and compare the features of our current and future instruments.

Model 676 Arb



- Analog Channels: 2
- Digital Channels: 32
- Multi-Channel: 8 Analog / 128 Digital
- Sample Rate: 2.5 GS/s
- Resolution: 14 Bits
- Output Frequency Range: 1 GHz
- AWG and AFG Mode
- Analog Output:
 - Direct DAC: 1.6Vpp @ 100 Ohm Diff. / 0.8Vpp @ 50 Ohm SE.
 - DC Amp: 10Vpp @ 100 Ohm Diff. / 5Vpp @ 50 Ohm SE.
 - AC Output: 2Vpp @ 50 Ohm SE.